

Programmable Telephone Audio Processor

Description

The programmable telephone audio processor U4091B is a linear integrated circuit for use in feature phones, answering machines and fax machines. It contains the speech circuit, tone ringer interface with dc/dc converter, sidetone equivalent and ear protection rectifiers. The circuit is line powered and contains all components necessary for amplification of signals and adaptation to the line.

An integrated voice switch with loudspeaker amplifier allows handsfree or loudhearing operation. With an anti-feedback function, acoustical feedback during loudhearing can be reduced significantly. The generated supply voltage is suitable for a wide range of peripheral circuits.

Features

- Speech circuit with anti-clipping
- Tone ringer interface with dc / dc converter
- Speaker amplifier with anti-distortion
- Power supply management, regulated, unregulated and a special supply for electret microphone
- Voice switch

Benefits

- Savings of one piezo electric transducer
- Complete system integration of analog signal processing on one chip
- Very few external components

Applications

Feature phone, answering machine, fax machine, speaker phone

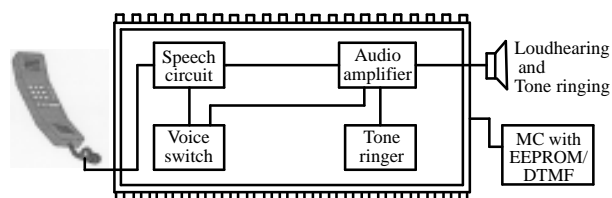

94 8741

Serial Bus Controlled Functions

Speech circuit

- Transmit gain: 36 to 52 dB (1 dB step)
- Receive gain: -4 dB to +4 dB (1 dB step) + one 8 dB step
- Speaker amplifier gain: -9 dB to +30 dB (3 dB step)
- Mute R , Mute T
- Automatic gain adjustment (AGA): 7 different characteristics
- Impedance selection: 600/ 900 Ω

Ringer

- Volume adjustment

Voice switch

- Volume adjustment
- Attenuation range: 0 to 50 dB (3.3 dB steps)
- 4 thresholds for mode switching
- Mute of handsfree microphone
- Chip disable
- Hand set / handsfree switching
- Two point level detection

Pin Description

Pin	Symbol	Function
	DTMF	Input for DTMF signals, also used for the answering machine and handsfree input
	MICO	Output of microphone preamplifier
	MIC 2	Non-inverting input of microphone amplifier
	MIC 1	Inverting input of microphone amplifier
	PD	Active high input for reducing the current consumption of the circuit, simultaneously V_L is shorted by an internal switch
	IND	The internal equivalent inductance of the circuit is proportional to the value of the capacitor at this pin, a resistor connected to ground may be used to reduce the dc line voltage
	V_L	Line voltage
	GND	Reference point for dc- and ac-output signals
	SENSE	A small resistor (fixed) connected from this pin to V_L sets the slope of the dc characteristic and also effects the line length equalization characteristics and the line current at which the loudspeaker amplifier is switched on
	V_B	Unregulated supply voltage for peripheral circuits (voice switch), limited to typically 7 V
	SAO	Output of loudspeaker amplifier
	V_{MPS}	Unregulated supply voltage for μP , limited to 6.3 V
	V_{MP}	Regulated supply voltage 3.3 V for peripheral circuits (especially microprocessors), maximum output current: 2 mA
	SWOUT	Output for driving external switching transistor
	COSC	40 kHz oscillator for ringing power converter
	VRING	Input for ringing signal
	THA	Threshold adjustment for ringing frequency detector
	RFDO	Output of ringing frequency detector
	LIDET	Line detect; output is low when the line current is more than 15 mA

Pin	Symbol	Function
	TSACL	Time constant of anti-clipping of speaker amplifier
	SA I	Speaker amplifier input (for loudspeaker, tone ringer and handsfree use)
	RLO1	Receive level output 1
	RLI1	Receive level input 1
	MICHF	Handsfree Mic input
	BNMT	Background noise monitor in transmit direction
	RLI2	Receive level input 2
	RLO2	Receive level output 2
	C	Clock
	D	Data
	Reset	Reset
	IREF	Internal reference current generation; RREF = 62 k Ω ; IREF = 20 μA
	STO	Side tone reduction output output resistance is approx. 300 Ω , maximum load impedance: 10 k Ω .
	V_M	Reference node for microphone-earphone and loudspeaker amplifier, supply for electret microphone ($IM \leq 300 \mu A$)
	RECO 2	Inverting output of receiving amplifier
	STI S	Input for side tone network (short loop) or for answering machine
	STI L	Input for side tone network (long loop)
	RAC	Input of receiving amplifier for ac coupling in feedback path
	RECO 1	Output of receiving amplifier
	TTXA	Time constant of anticlipping in transmit path
	RECIN	Input of receiving path; input impedance is typically 80 k Ω
	TXIN	Input of intermediate transmit stage, input resistance is typically 20 k Ω
	TLDI	Transmit level detector input
	TLDO	Time constant of level detector for transmit voice recognition
	TS	Time constant for switching

Absolute Maximum Ratings

Parameters	Symbol	Value	Unit
Line current	I_L	140	mA
DC line voltage	V_L	12	V
Maximum input current	I_{RING}	15	mA
Junction temperature	T_j	125	°C
Ambient temperature	T_{amb}	-25 to +75	°C
Storage temperature	T_{stg}	-55 to +150	°C
Total power dissipation, $T_{amb} = 60^\circ\text{C}$	P_{tot}	0.9	W

Thermal Resistance

Parameters	Symbol	Value	Unit
Junction ambient SSO44	R_{thJA}	70	K/W

Electrical Characteristics

$f = 1 \text{ kHz}$, $0 \text{ dBm} = 775 \text{ mV}_{\text{rms}}$, $I_M = 0.3 \text{ mA}$, $I_{MP} = 2 \text{ mA}$, $RDC = 130 \text{ k}\Omega$, $T_{\text{amb}} = 25^\circ\text{C}$, $RGSA = 560 \text{ k}\Omega$,
 $Z_{\text{ear}} = 68 \text{ nF} + 100 \text{ }\Omega$, $Z_M = 68 \text{ nF}$, $V_{\text{IMPSEL}} = \text{GND}$, $V_{\text{MUTX}} = \text{GND}$, $V_{\text{MUTR}} = \text{GND}$, unless otherwise specified.

Parameters	Test Conditions / Pin	Symbol	Min.	Typ.	Max.	Unit	Figure
DC characteristics							
DC voltage drop over circuit	$I_L = 2 \text{ mA}$ $I_L = 14 \text{ mA}$ $I_L = 60 \text{ mA}$ $I_L = 100 \text{ mA}$	V_L	4.6	2.4 5.0 7.5 9.4	5.4 10.0	V	
Transmission amplifier, $I_L = 14 \text{ mA}$, $V_{\text{MIC}} = 2 \text{ mV}$, $RGT = 27 \text{ k}\Omega$, unless otherwise specified							
Adjustment range of transmit gain		G_T	36		52	dB	
Transmitting amplification		G_T	47	48	49	dB	
Frequency response	$I_L \geq 14 \text{ mA}$, $f = 300 \text{ to } 3400 \text{ Hz}$	ΔG_T			± 0.5	dB	
Gain change with current	Pin 31 open $I_L = 14 \text{ to } 100 \text{ mA}$	ΔG_T			± 0.5	dB	
Gain deviation	$T_{\text{amb}} = -10 \text{ to } +60^\circ\text{C}$	ΔG_T			± 0.5	dB	
CMRR of microphone amplifier		CMRR	60	80		dB	
Input resistance of MIC amplifier	$RGT = 12 \text{ k}\Omega$ $RGT = 27 \text{ k}\Omega$	R_i	45	50 75	110	$\text{k}\Omega$	
Distortion at line	$I_L > 14 \text{ mA}$ $V_L = 700 \text{ mV}_{\text{rms}}$	d_t			2	%	
Maximum output voltage	$I_L > 19 \text{ mA}$ $d < 5\%$ $V_{\text{mic}} = 25 \text{ mV}$ $CTXA = 1 \text{ }\mu\text{F}$	$V_{L\text{max}}$	1.8	3	4.2	dBm	
Noise at line psophometrically weighted	$I_L > 14 \text{ mA}$ $G_T = 48 \text{ dB}$	no		-80	-72	dBmp	
Anti-clipping attack time release time	$CTXA = 1 \text{ }\mu\text{F}$ each 3 dB overdrive			0.5 9		ms	
Gain at low operating current	$I_L = 10 \text{ mA}$ $I_{MP} = 1 \text{ mA}$ $RDC = 68 \text{ k}\Omega$ $V_{\text{mic}} = 1 \text{ mV}$ $I_M = 300 \text{ }\mu\text{A}$	G_T	40		42.5	dB	
Distortion at low operating current	$I_L = 10 \text{ mA}$ $I_M = 300 \text{ }\mu\text{A}$ $I_{MP} = 1 \text{ mA}$ $RDC = 68 \text{ k}\Omega$ $V_{\text{mic}} = 10 \text{ mV}$	d_t			5	%	
Line loss compensation	$I_L = 100 \text{ mA}$	ΔG_{TI}	-6.4	-5.8	-5.2	dB	
Mute suppression	$I_L \geq 14 \text{ mA}$	G_{TM}	60	80		dB	
a) MIC muted (microphone preamplifier)	Mutx = open						
b) TXA muted (second stage)	IMPSEL = open	G_{TTX}	60			dB	

Parameters	Test Conditions / Pin	Symbol	Min.	Typ.	Max.	Unit	Figure
Receiving amplifier, $I_L = 14$ mA, RGR = 62 k, unless otherwise specified, $V_{GEN} = 300$ mV							
Adjustment range of receiving gain	$I_L \geq 14$ mA, single ended differential MUTR = GND	G_R	-4		+12	dB	
Receiving amplification	RGR = 62 k Ω differential	G_R	-1.75	-1	-0.25	dB	
Amplification of DTMF signal from DTMF IN to RECO 1, 2	$I_L \geq 14$ mA $V_{MUTX} = V_{MP}$	G_{RM}	7	10	13	dB	
Frequency response	$I_L > 14$ mA, $f = 300$ to 3400 Hz	ΔG_{RF}			± 0.5	dB	
Gain change with current	$I_L = 14$ to 100 mA	ΔG_R			± 0.5	dB	
Gain deviation	$T_{amb} = -10$ to $+60^\circ\text{C}$	ΔG_R			± 0.5	dB	
Ear protection differential	$I_L \geq 14$ mA $V_{GEN} = 11$ Vrms	EP			2.2	Vrms	
MUTE suppression a) RECATT b) RA2 c) DTMF operation	$I_L \geq 14$ mA MUTR = open $V_{MUTR} = V_{MP}$ $V_{MUTX} = V_{MP}$	ΔG_R	60			dB	
Output voltage $d \leq 2\%$ differential	$I_L = 14$ mA $Z_{ear} = 68$ nF + 100 Ω		0.775			Vrms	
Maximum output current $d \leq 2\%$	$Z_{ear} = 100$ Ω		4			mA (peak)	
Receiving noise psophometrically weighed	$Z_{ear} = 68$ nF + 100 Ω $I_L \geq 14$ mA	ni		-80	-77	dBmp	
Output resistance	each output against GND	R_o			10	Ω	
Line loss compensation	RAGA = 20 k Ω , $I_L = 100$ mA	ΔG_{RI}	-7.0	-6.0	-5.0	dB	
Gain at low operating current	$I_L = 10$ mA $I_{MP} = 1$ mA $I_M = 300$ μA $V_{GEN} = 560$ mV RDC = 68 k Ω	G_R	-2	-1	0	dB	
AC impedance	$V_{IMPSEL} = \text{GND}$ $V_{IMPSEL} = V_{MP}$	Z_{imp} Z_{imp}	570 840	600 900	640 960	Ω Ω	
Distortion at low operating current	$I_L = 10$ mA $I_{MP} = 1$ mA $V_{GEN} = 560$ mV RDC = 68 k Ω	dR			5	%	

Parameters	Test Conditions / Pin	Symbol	Min.	Typ.	Max.	Unit	Figure
Speaker Amplifier							
Minimum line current for operation	No ac signal	I_{Lmin}			15	mA	
Input resistance			14		22	k Ω	
Gain from SAI to SAO	$V_{SAI} = 3 \text{ mV}$, $R_{GSA} = 20 \text{ k}\Omega$	G_{SA}	30	31 - 3	32	dB	
Output power	Load resistance $R_L = 50 \Omega$, $d < 5\%$ $V_{SAI} = 20 \text{ mV}$ $I_L = 20 \text{ mA}$	P_{SA} P_{SA}		t.b.d.		mW	
Output noise (Input SAI open) psophometrically weighted		n_{SA}			200	μV_{psoph}	
Gain deviation	$T_{amb} = -10 \text{ to } +60^\circ\text{C}$	ΔG_{SA}			± 1	dB	
Mute suppression	$V_L = 0 \text{ dBm}$, $V_{SAI} = 4 \text{ mV}$ Pin 23 open	VSAO			-60	dBm	
Gain change with current		ΔG_{SA}			± 1	dB	
Gain change with frequency	$f = 300 \text{ to } 3400 \text{ Hz}$	ΔG_{SA}			± 0.5	dB	
Attack time of anti-clipping	20 dB over drive	tr		5		ms	
Release time of anti-clipping		tf		80		ms	
DTMF-Amplifier Test conditions: IMP = 2 mA, IM = 0.3 mA, V_{MUTX} = VMP							
Adjustment range of DTMF gain	$I_L = 15 \text{ mA}$ Mute active	G_D	40		48	dB	
DTMF amplification	$I_L = 15 \text{ mA}$, $V_{DTMF} = 8 \text{ mV}$ Mute active: $MUTX = VMP$	G_D	40.7	41.7	42.7	dB	
Gain deviation	$I_L = 15 \text{ mA}$ $T_{amb} = -10 \text{ to } +60^\circ\text{C}$	G_D			± 0.5	dB	
Input resistance	$R_{GT} = 27 \text{ k}\Omega$, $R_{GT} = 15 \text{ k}\Omega$	R_i	60 26	180 70	300 130	k Ω	
Distortion of DTMF signal	$I_L \geq 15 \text{ mA}$ $V_L = 0 \text{ dBm}$	d_D			2	%	
Gain deviation with current	$I_L = 15 \text{ to } 100 \text{ mA}$	ΔG_D			± 0.5	dB	
AFS Acousting feedback suppression							
Adjustment range of attenuation			0		50	dB	

Parameters	Test Conditions / Pin	Symbol	Min.	Typ.	Max.	Unit	Figure
Supply voltages, $V_{mic} = 25 \text{ mV}$, $T_{amb} = -10 \text{ to } +60^\circ\text{C}$							
V_{MP}	$I_L = 14 \text{ mA}$, RDC = 68 k Ω $I_{MP} = 2 \text{ mA}$	V_{MP}	3.1	3.3	3.5	V	
V_{MPS}	$I_L = 100 \text{ mA}$ RDC = inf., $I_{MP} = 0 \text{ mA}$	V_{MPS}			6.7	V	
V_M	$I_L \geq 14 \text{ mA}$, $I_M = 300 \mu\text{A}$ RDC = 130 k Ω	V_M	1.4		3.3	V	
V_B	$I_B = +20 \text{ mA}$, $I_L = 0 \text{ mA}$	V_B		7	7.6	V	
Ring power converter, $IMP = 1 \text{ mA}$, $IM = 0$							
Maximum output power	$V_{RING} = 20.6 \text{ V}$	P_{SA}		20		mW	
Threshold of ring frequency detector	RFDO: low to high $V_{HYST} = V_{RINGON} - V_{RINGOFF}$	V_{RINGON} V_{HYST}		17.5 11.0		V	
Input impedance	$V_{RING} = 30 \text{ V}$	R_{RING}	4	5	6	k Ω	
Input impedance in speech mode	$f = 300 \text{ Hz to } 3400 \text{ Hz}$ $I_L > 15 \text{ mA}$, $V_{RING} = 20\text{V} + 1.5V_{rms}$	R_{RINGSP}	150			k Ω	
Logic-level of frequency detector	$V_{RING} = 0 \text{ V}$, $V_B = 4 \text{ V}$ $V_{RING} = 25 \text{ V}$	V_{RFDO}		0 VMP		V	
PD Input							
PD input current	PD active, $I_L > 14 \text{ mA}$ $V_{PD} = V_{MP}$	I_{pd}		9		μA	
Input voltage	PD = active PD = inactive	V_{pd} V_{pd}	2		0.3	V	
Voltage drop at V_L	$I_L = 14 \text{ mA}$, PD = active $I_L = 100 \text{ mA}$, PD = active	V_L V_L		1.5 1.9		V	
Line detection							
Line current for LIDET active	PD = inactive	ILON		12.6		mA	
Line current for LIDET inactive	PD = inactive	ILOFF		11.0		mA	
Current threshold during power down	$V_B = 5 \text{ V}$, PD = active	ILONPD	0.8	1.6	2.4	mA	

U4091B – Control

IMPSEL		MODE
0	Line-impedance = 600 Ω TXA = on ES = off	Speech
0 to Z	Line-impedance = 600 Ω TXA = off ES = on	Transmit-mute
1 to Z	Line-impedance = 900 Ω TXA = off ES = on	Transmit-mute
1	Line-impedance = 900 Ω TXA = on ES = off	Speech

MUTX		MODE
0	MIC 1/2 transmit enabled receive enable AFS = on AGA = on TXACL = on	Speech
Z	DTMF transmit enabled receive enable AFS = on AGA = on TXACL = on	For answering machine
1	DTMF transmit enabled DTMF to receive enable AFS = off AGA = off TXACL = off	DTMF dialling

MUTR		MODE
0	RA2 = on RECATT = on STIS + STIL = on	Speech
0 to Z	RA2 = on RECATT = off STIS = on, STIL = off	For answering machine
1 to Z	RA2 = off RECATT = off STIS = on, STIL = off AGA off for STIS	For answering machine
1	RA2 = off RECATT = on STIS + STIL = on	Speech + ear-peace mute

Logic-level
0 = < (0.3 V)
Z = > (1 V) < (VMP – 1 V) or (open input)
1 = > (VMP – 0.3 V)

RECATT = Receive attenuation
 STIS, STIL = Inputs of sidetone balancing amplifiers
 ES = External supply
 AFS = Acoustical feedback suppression control
 AGA = Automatic gain adjustment
 RA2 = Inverting receive amplifier
 TXACL = Transmit anticlippping control

All above operating modes are programmable!

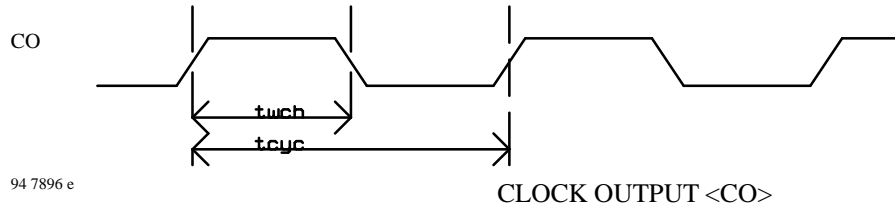

Serial Bus

The circuit is remoted by an external microcontroller through the serial bus:

The data is an 8-bit word:

B7 – B6 – B5: address of the destination register (0 to 7)

B4 – B0: contents of register

The data line must be stable when the clock is high and data must be serially shifted.

After 8 clock periods, the transfer to the destination register is (internally) generated by a low to high transition of the data line when the clock is high.

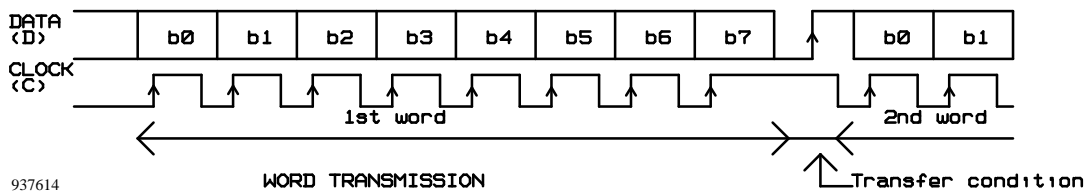
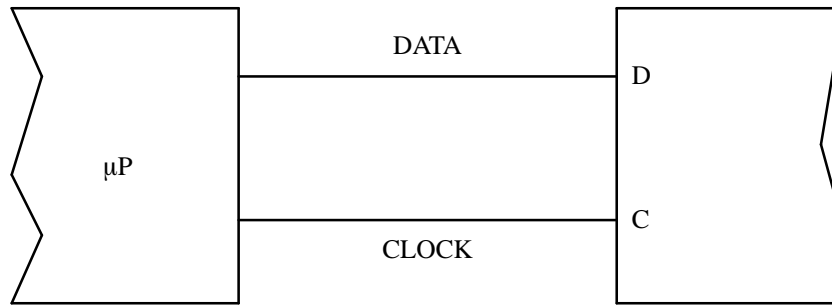

Serial Bus Interface

8 bits register

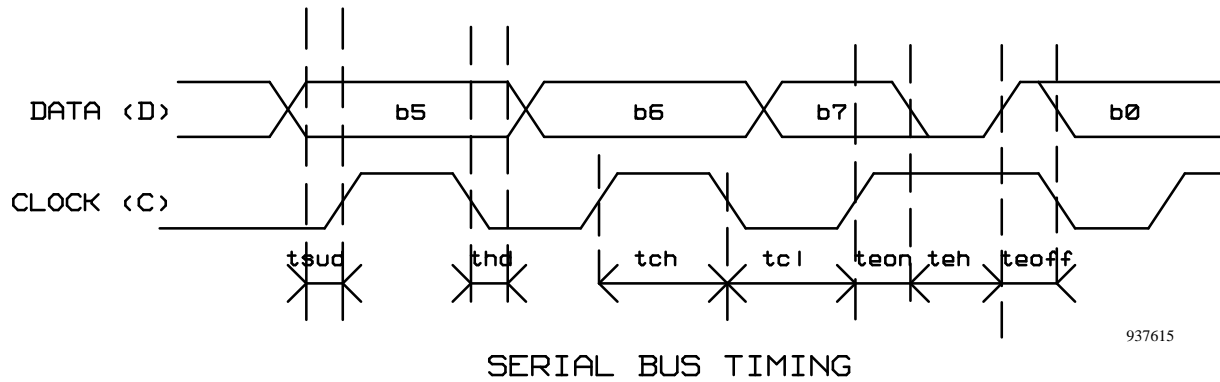
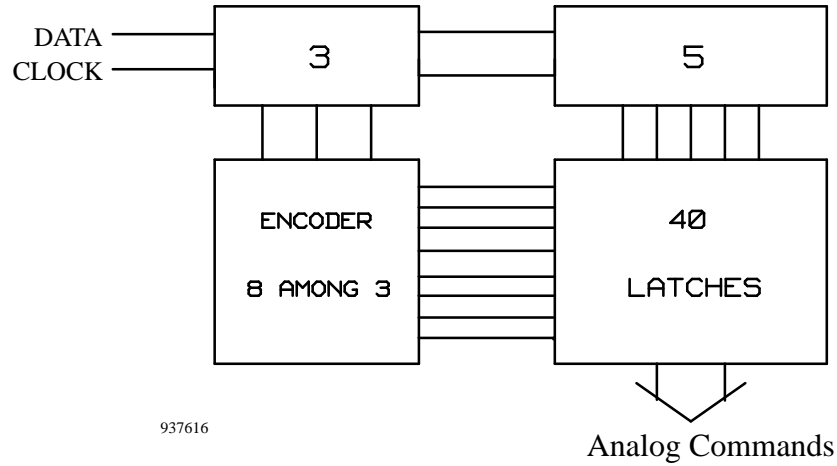

Ozone Depleting Substances Policy Statement

It is the policy of **TEMIC TELEFUNKEN microelectronic GmbH** to

1. Meet all present and future national and international statutory requirements.
2. Regularly and continuously improve the performance of our products, processes, distribution and operating systems with respect to their impact on the health and safety of our employees and the public, as well as their impact on the environment.

It is particular concern to control or eliminate releases of those substances into the atmosphere which are known as ozone depleting substances (ODSs).

The Montreal Protocol (1987) and its London Amendments (1990) intend to severely restrict the use of ODSs and forbid their use within the next ten years. Various national and international initiatives are pressing for an earlier ban on these substances.

TEMIC TELEFUNKEN microelectronic GmbH semiconductor division has been able to use its policy of continuous improvements to eliminate the use of ODSs listed in the following documents.

1. Annex A, B and list of transitional substances of the Montreal Protocol and the London Amendments respectively
2. Class I and II ozone depleting substances in the Clean Air Act Amendments of 1990 by the Environmental Protection Agency (EPA) in the USA
3. Council Decision 88/540/EEC and 91/690/EEC Annex A, B and C (transitional substances) respectively.

TEMIC can certify that our semiconductors are not manufactured with ozone depleting substances and do not contain such substances.

We reserve the right to make changes to improve technical design and may do so without further notice.

Parameters can vary in different applications. All operating parameters must be validated for each customer application by the customer. Should the buyer use TEMIC products for any unintended or unauthorized application, the buyer shall indemnify TEMIC against all claims, costs, damages, and expenses, arising out of, directly or indirectly, any claim of personal damage, injury or death associated with such unintended or unauthorized use.

TEMIC TELEFUNKEN microelectronic GmbH, P.O.B. 3535, D-74025 Heilbronn, Germany
Telephone: 49 (0)7131 67 2831, Fax number: 49 (0)7131 67 2423